

Gear couplings

Types and operating description 86

BoWex®

Technical data	88
Displacements	89
Cylindrical and taper bores and selection of standard IEC motors	90
Type junior and junior M plug-in couplings made of nylon	91
Type M, type I and type M...C with explosion protection	92
Type AS and type Spec.-I	94
Type SG, type SSR and type Spec.-I/CD	95
Type SD / SD-D	96
Type SD1 with slip ring and shiftable linkage	98
Type GT	100
Type ZR with a long PA sleeve	101
Type HEW Compact	102
Type M made of corrosion-resistant materials	104
Taper bores	106
Spline hubs and inch bores	107



GEARex®

Type FA, FB and FAB	108
Type DA, DB and DAB	110
Type FH and DH	112
Type FR and DR	114
Displacements	116
Flange dimensions in accordance with AGMA 9008-B00	117

Please note: torque increase



Years of experience with applications at customer sites and additional test series in the KTR test field in Rheine enabled us to determine potentials allowing for an increase of rated torques with some sizes of this series.

BoWex®



GEARex®



GEAR COUPLINGS

TYPES AND OPERATING DESCRIPTION

Properties of gear couplings

		
Product	BoWex®	GEARex®
Type	Curved-tooth gear coupling*	All-steel gear coupling
Features		
AGMA		●
Torsionally rigid	●	●
Damping vibrations	HEW Compact	
Maintenance-free	●	
Axial plug-in	●	
Compensating for misalignment	●	●
Fail-safe		●
Shear type	●	
Electrical insulation	●	○
Special features		
Variation	very high extensive basic programme available from stock while customised solutions can be realized	average extensive basic programme available from stock while customised solutions can be realized
Applications / core industries	pump drives, general engineering & hydraulics, food industry, ...	heavy engineering transport, logistics, cement industry, ...
Torque range T_{KN} [Nm]		
Max.	2,500	2,750,000
Speed range n [rpm] *		
Max.	14,000	8,500
Hub materials available		
Nylon	●	
Quality steel (C45)	Size 65 - 125	up to size 85
Alloyed Q & T steel (42CrMo4V)		from size 90
Powder metal steel » subject to mould	Size 14 - 65	
Stainless steel	●	
Other special materials possible	●	●
Corrosion-protected types	○	○
Sleeve (standard and special)		
Material	polyamide, polyamide with carbon fibre share, natural rubber	-
Elastomer	highly flexible	-
Temperature range [°C] min./max.		
Standard	-25/+100	-20/+80
Special	-50/+120	-40/+120

- ≈ Standard
- ≈ On request
- * ≈ Depending on size





In KTR's Power Transmission Center the performance of our products is subjected to testing. Great emphasis is put on quality assurance.

GEAR COUPLINGS

TYPES AND OPERATING DESCRIPTION

Product finder of gear couplings

Product	BoWex®	GEARex®
Type	Curved-tooth gear coupling®	All-steel gear coupling
Geometries		
Design	compact	short/compact
Mass moment of inertia	low	average
Shaft distance dimension	very low	very low
Types (extract)		
Shiftable coupling type	SD, SD-1, SD-D, SD-D3	SD
Flange type	-	FA, FB, FAB, FH, FR
Cover type	-	DA, DB, DAB, DH, DR
Suitable for horizontal assembly	Standard	Standard
Suitable for vertical assembly	Standard	VD
Sleeve can be disassembled radially » with no need of displacing driving/driven side	GT	-
Intermediate shaft types » bridging larger shaft distances	ZR	FH, DH
Single-cardanic	HEW Compact	FR, DR
Double-cardanic » compensating for big displacements » lower restoring forces	Standard	Standard
Certifications/type examinations		
ATEX 	●	●
DNV/GL 	●	●
Bureau Veritas 	●	
ABS 		●
GOST R/GOST TR 	●	
Curved-tooth gear principle 	●	●

● ≈ Standard

Details on spline

Hub with crowned spline (BoWex® and GEARex®)

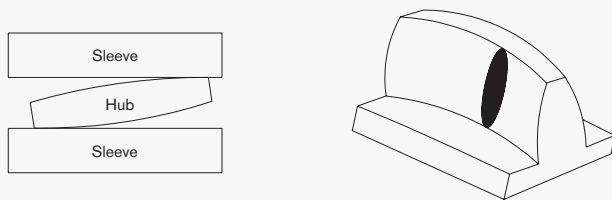

Based on the operating principle of the well-known crowned gear, edge pressure in the spline is avoided with angular and radial displacements.

BoWex®:

The smooth and hard surface of the BoWex® sleeve (crystalline structure) and the high thermal stability and resistance to lubricants, fuels, hydraulic fluids, solvents, etc. make polyamide an ideal material for components stressed by sliding, particularly for coupling manufacture.

GEARex®:

In order to ensure regular and controlled lubrication in assembled condition, two connections for hydraulics are arranged opposite to each other radially on each coupling sleeve. Accordingly a complete GEARex® coupling has four connections being offset to each other by 90°.

Hub with spur toothing

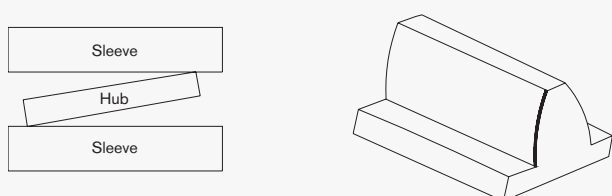

BoWex® Curved-tooth gear coupling®

Technical data

Power, torque and speed							
Type and size		Power P [kW] / n [rpm]		Torque [Nm]			Max. speed [rpm]
		Rated	Max.	T _{KN}	T _{K max}	T _{KW}	
Type plug-in coupling/ junior M	junior 14 / M-14	0.0005	0.010	5	10	2.5	6000
	junior 19 / M-19	0.0008	0.0017	8	16	4	6000
	junior 24 / M-24	0.0013	0.0025	12	24	6	6000
Type M AS Spec.-I SG SSR	14	0.0010	0.003	10	30	5	14000
	19	0.0017	0.005	16	48	8	11800
	24	0.0021	0.006	20	60	10	10600
	28	0.0047	0.014	45	135	23	8500
	32	0.0063	0.019	60	180	30	7500
	38	0.0084	0.025	80	240	40	6700
	42	0.010	0.031	100	300	50	6000
	45 / 48	0.015	0.044	140	420	70	5600
	65	0.040	0.119	380	1140	190	4000
	80	0.073	0.22	700	2100	350	3150
	100	0.13	0.38	1200	3600	600	3000
	125	0.26	0.78	2500	7500	1250	2120
Type M...C GT	14	0.0015	0.0047	15	45	7.5	14000
	19	0.0025	0.0075	24	72	12	11800
	24	0.003	0.009	30	90	15	10600
	28	0.007	0.022	70	210	35	8500
	32	0.009	0.028	90	270	45	7500
	38	0.013	0.038	120	360	60	6700
	48	0.021	0.063	200	600	100	5600
	65	0.058	0.18	560	1680	280	4000
Type HEW Compact	T50 Sh	0.0236	0.0471	200	400	50	7300
	42-130 T65 Sh	0.0283	0.0565	270	540	68	7300
	T70 Sh	0.0330	0.0660	320	640	80	7300
	T50 Sh	0.0628	0.1257	550	1100	138	5500
	65-180 T65 Sh	0.0785	0.1571	740	1500	185	5500
	T70 Sh	0.0890	0.1780	860	1700	215	5500
	T50 Sh	0.1414	0.2827	1250	2500	313	4400
	80-225 T65 Sh	0.1728	0.3455	1600	3200	400	4400
	T70 Sh	0.2042	0.4084	1900	3800	475	4400
	T50 Sh	0.3141	0.6283	2750	5500	688	3200
	100-305 T65 Sh	0.4084	0.8168	3900	7800	975	3200
	T70 Sh	0.4712	0.9424	4500	9000	1125	3200
	T50 Sh	0.6283	1.2565	5500	11000	1375	2900
	125-365 T65 Sh	0.7853	1.5707	7500	15000	1875	2900
	T70 Sh	0.8901	1.7801	8400	16800	2100	2900

Setscrews

Thread dimensions for setscrews, BoWex® coupling hubs with cylindrical bore.

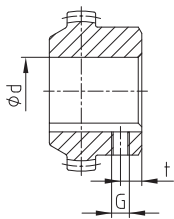

Position of the setscrew BoWex® M-14 to M-24 opposite the keyway

BoWex® M-28 to I-125 on the keyway

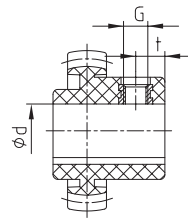

Position of thread with BoWex® junior plug-in coupling and junior M coupling

BoWex® coupling hubs							
Size Dimensions	14 19 24	28 32 38	42 45 48	65	80	100	125
Thread G	M5	M8	M10	M10	M12	M16	
Distance t	6	10	15 ¹⁾ 20	20	30	40	
Tightening torque T _A [Nm]	2	10	17	17	40	80	

BoWex® junior coupling hubs			
Size Dimensions	14	19	24
Thread G	M5	M5	M5
Hub 1b - Distance t	6	6	6
Plug-in sleeve 2b - Distance t	8	10	10
Tightening torque T _A [Nm]	1.4	1.4	1.4

¹⁾ Length of hub 55 mm t = 15 mm, 70 mm t = 20 mm

BoWex® Curved-tooth gear coupling®

Types of hubs

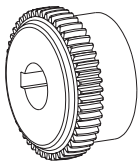

Type 1.0 hub with feather keyway and setscrew

Positive-locking power transmission, permissible torque depending on the permissible surface pressure. Not suitable for backlash-free power transmission with heavily reversing operation.

Type 1.1 hub without feather keyway, with setscrew

Non-positive torque transmission for crimp connections and adhesive bonds. (No ATEX approval)

Type 1.3 hub with spline bore (see page 107)

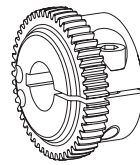

Type 2.0 clamping hub single slot without feather keyway

Frictionally engaged, backlash-free shaft-hub-connection. Transmittable torques depending on bore diameter.

Type 2.1 clamping hub single slot with feather keyway

Positive-locking power transmission with additional friction fit. The friction fit avoids or reduces reverse backlash. Surface pressure of the keyway connection is reduced.

Type 2.3 clamping hub with spline bore (see page 107)

Other hub types on request.

Displacements

BoWex® couplings are double-cardanic compensating for axial, radial and angular shaft displacements in addition to transmitting the power so that damage on the driving or driven machine is prevented.

Axial displacement

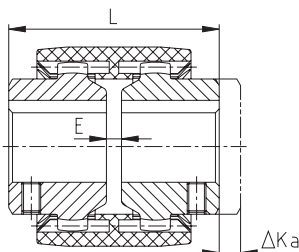

Radial displacement

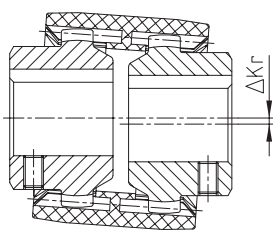

Angular displacement

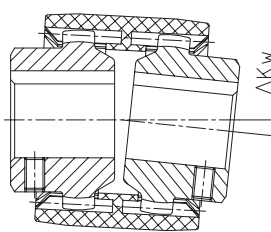

Radial and angular displacement

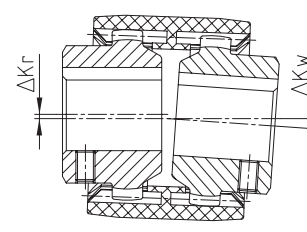

Displacements – type junior couplings

BoWex® size	Type junior plug-in coupling			Type junior M		
	14	19	24	14	19	24
Max. axial displacement ΔK_a [mm]	± 1	± 1	± 1	± 1	± 1	± 1
Max. radial displacement with $n=1500$ rpm ΔK_r [mm]	± 0.1	± 0.1	± 0.1	± 0.3	± 0.3	± 0.4
Max. radial displacement with $n=3000$ rpm ΔK_r [mm]	± 0.1	± 0.1	± 0.1	± 0.3	± 0.3	± 0.4
Max. angular displacement with $n=1500$ rpm ΔK_w [degree]	± 1.0	± 1.0	± 0.9	± 1.0	± 1.0	± 0.9
Max. angular displacement with $n=3000$ rpm ΔK_w [degree]	± 0.7	± 0.7	± 0.6	± 0.7	± 0.7	± 0.6

Displacements – type M, I, AS, Spec.-I, SG and SSR

BoWex® size	14	19	24	28	32	38	42	48	65	80	100	125
Max. axial displacement ΔK_a [mm]	± 1	± 1	± 1	± 1	± 1	± 1	± 1	± 1	± 1	± 1	± 1	± 1
Max. radial displacement with $n=1500$ rpm ΔK_r [mm]	± 0.30	± 0.30	± 0.35	± 0.35	± 0.35	± 0.40	± 0.40	± 0.40	± 0.45	± 0.45	± 0.45	± 0.45
Max. radial displacement with $n=3000$ rpm ΔK_r [mm]	± 0.20	± 0.20	± 0.23	± 0.23	± 0.23	± 0.25	± 0.25	± 0.25	± 0.28	± 0.28	± 0.28	± 0.28
Max. angular displacement with $n=1500$ rpm ΔK_w [degree]	± 1.0	± 1.0	± 0.9	± 0.9	± 0.9	± 0.9	± 0.9	± 0.9	± 0.7	± 0.6	± 0.6	± 0.4
Max. angular displacement with $n=3000$ rpm ΔK_w [degree]	± 0.7	± 0.7	± 0.6	± 0.6	± 0.6	± 0.6	± 0.6	± 0.6	± 0.5	± 0.4	± 0.4	± 0.3

Displacements – type GT

Displacements – type HEW Compact

BoWex® size	Displacements – type GT				Displacements – type HEW Compact																
	28	38	48	65	42-130			65-180			80-225			100-305			125-365				
					T50	T65	T70	T50	T65	T70	T50	T65	T70	T50	T65	T70	T40	T52	T65		
Max. axial displacement ΔK_a [mm]	± 1	± 1	± 1	± 1	± 2			± 2			± 2			± 2			± 2				
Max. radial displacement with $n=1500$ rpm ΔK_r [mm]	± 1	± 1	± 1.4	± 1.4	± 1.1	± 1	± 0.5	± 1.6	± 1.5	± 0.7	± 1.8	± 1.7	± 2.2	± 2.2	± 2	± 2	± 1	± 2.5	± 2.3	± 1.1	
Max. radial displacement with $n=3000$ rpm ΔK_r [mm]	± 0.6	± 0.6	± 1	± 1	± 0.55	± 0.5	± 0.25	± 0.8	± 0.75	± 0.35	± 0.9	± 0.85	± 1.1	± 1.1	± 1	± 1	± 0.5	± 1.25	± 1.15	± 0.55	
Max. angular displacement with $n=1500$ rpm ΔK_w [degree]	± 1	± 1	± 0.9	± 0.9	± 1	± 0.75	± 0.5	± 1	± 0.75	± 0.5	± 1	± 0.75	± 1	± 1	± 1	± 1	± 0.75	± 0.5	± 1	± 0.75	± 0.5
Max. angular displacement with $n=3000$ rpm ΔK_w [degree]	± 0.7	± 0.7	± 0.6	± 0.6	± 0.5	± 0.4	± 0.25	± 0.5	± 0.4	± 0.25	± 0.5	± 0.4	± 0.25	± 0.5	± 0.5	± 0.25	± 0.25	± 0.5	± 0.4	± 0.25	

The permissible displacement figures of the BoWex® couplings specified are general standard values taking into account the load of the coupling up to the rated torque T_{KN} of the coupling. With different operating conditions please order our data sheet for displacements of BoWex® KTR-N 20140. The displacement figures may only be used one by one, if they appear simultaneously, they must be limited in proportion. Care should be taken to maintain the distance dimension E accurately in order to allow for axial clearance of the coupling while in operation. Detailed mounting instructions are shown on our homepage www.ktr.com.

BoWex® Curved-tooth gear coupling®

Cylindrical bores, taper/inch bores see selection of standard IEC motors

Stock programme of cylindrical finish bores [mm] H7 feather keyway acc. to DIN 6885 sheet 1 [JS9] and setscrew																														
BoWex® Size	un/pilot bored	Ø8	Ø10	Ø11	Ø12	Ø14	Ø15	Ø16	Ø17	Ø18	Ø19	Ø20	Ø22	Ø24	Ø25	Ø28	Ø30	Ø32	Ø35	Ø38	Ø40	Ø42	Ø45	Ø48	Ø50	Ø55	Ø60	Ø65	Ø70	Ø75
14	●■	●	●	●	●	●	●																							
19	●■		●	●	●	●	●	●	●	●	●■	●																		
24	●■		●	●	●	●■	●	●	●	●	●■	●■	●	●■	●															
28	●■				●	●	●	●	●	●	●	●	●	●	●	●■														
32	●■							●		●	●	●	●	●	●	●	●	●	●											
38	●■							●		●	●	●	●	●	●	●	●	●	●	●■										
42	●■									●	●	●	●	●	●	●	●	●	●	●	●	●	●	●	●					
48	●■										●	●	●	●	●	●	●	●	●	●	●	●	●■	●■	●■					
65	●■											●	●	●	●	●	●	●	●	●	●	●■	●■	●■	●■	●■	●■	●■	●■	●■
80	●																						●	●	●	●	●	●	●	

● Standard length ■ Standard lengthened

Stock programme of taper and inch bores																			
Code d +0,05 b JS9 t +0.2	Taper 1:5					Taper 1:8					Inch bores								
	A-10 9.85 2	B-17 16.85 3	C-20 19.85 4	D-25 24.85 5	E-30 29.85 6	N/1 9.7 2.4	N1d 14 3	N/2 17.28 3.2	N/2a 17.28 4	N/3 22 3.99	Ta 12.7 3.17 14.3	DNC 13.45 3.17 14.9	Ed 15.87 4.75 18.1	A 19.05 4.78 21.3	G 22.22 4.75 24.7	F 22.22 6.38 25.2	Bs 25.38 6.37 28.3	Hs 25.4 6.35 28.7	K 31.75 7.93 35.4
14	●																		
19		●																	
24	●	●																	
28	●	●																	
32		●																	
38		●																	
42		●		●															
48																			
65																			

Other dimensions on request.

BoWex® couplings for standard IEC motors, protection class IP 54/IP 55										
A. C. motor Size	Motor power with 50 Hz n = 3000 [rpm]			Motor power with 50 Hz n = 1500 [rpm]			Motor power with 50 Hz n = 1000 [rpm]			Cylindrical shaft ends d x l [mm] 3000 ≤ 1500
	kW	T [Nm]	BoWex® coupling	kW	T [Nm]	BoWex® coupling	kW	T [Nm]	BoWex® coupling	
56	0.09	0.32		0.06	0.43		0.037	0.43		9 x 20
	0.12	0.41		0.09	0.64		0.045	0.52		
63	0.18	0.62	14	0.12	0.88	14	0.06	0.72	14	11 x 23
	0.25	0.86		0.18	1.3		0.09	1.1		
71	0.37	1.3	19	0.25	1.8	19	0.18	2.0	19	14 x 30
	0.55	1.9		0.37	2.5		0.25	2.7		
80	0.75	2.5	24	0.55	3.7	24	0.37	3.9	24	19 x 40
	1.1	3.7		0.75	5.1		0.55	5.8		
90 S	1.5	5.0	28	1.1	7.5	28	0.75	8.0	28	24 x 50
90 L	2.2	7.4		1.5	10		1.1	12		
100 L	3	9.8	38	2.2	15	38	1.5	15	38	28 x 60
				3	20		3	20		
112 M	4	13	42	4	27	42	2.2	22	42	38 x 80
132 S	5.5	18		5.5	36		3	30		
132 M	7.5	25	48	7.5	49	48	4	40	48	42 x 110
				5.5	55		5.5	55		
160 M	11	36	55	11	72	55	7.5	75	55	60 x 140
160 L	15	49		15	98		11	108		
180 M	18.5	60	65	18.5	121	65	15	148	65	75 x 140
180 L	22	71		22	144		15	148		
200 L	30	97	80	30	196	80	18.5	181	80	80 x 170
	37	120		30	196		22	215		
225 S			100	37	240	100			100	85 x 170
225 M	45	145		45	292		30	293		
250 M	55	177	125	55	356	125	37	361	125	95 x 170
280 S	75	241		75	484		45	438		
280 M	90	289	150	90	581	150	55	535	150	95 x 170
315 S	110	353		110	707		75	727		
315 M	132	423	175	132	849	175	90	873	175	95 x 170
	160	513		160	1030		110	1070		
315 L	200	641	200	200	1290	200	132	1280	200	95 x 170
							160	1550		
315	250	801	250	250	1610	250	200	1930	250	95 x 170
	315	1010		315	2020		250	2420		
355	355	1140	355	355	2280	355			355	95 x 170
	400	1280		400	2560		315	3040		

Torque T ^Δ = rated torque according to Siemens catalogue.

BoWex® junior and junior M Curved-tooth gear coupling®

Plug-in coupling made of nylon (two-part and three-part)



For legend of pictogram please refer to flapper on the cover

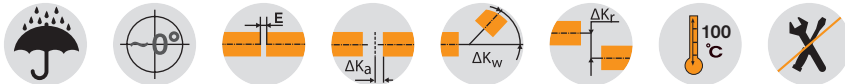

Components

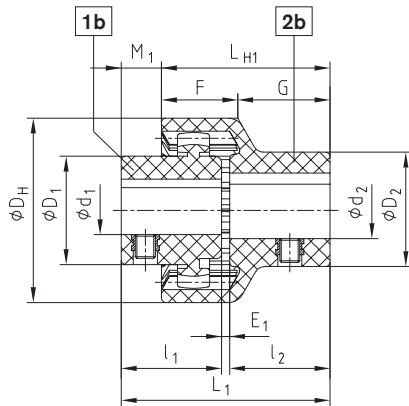

Type junior plug-in coupling (two-part)

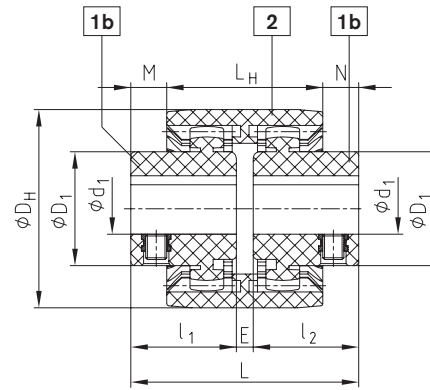

Type junior M coupling (three-part)

BoWex® junior plug-in coupling (two-part) and BoWex® junior M (three-part)																			
Size	Torque [Nm]		Finish bore				Dimensions [mm]										Max. speed [rpm]		
			Hub Component 1b ¹⁾		Plug-in sleeve Component 2b ¹⁾		D _H	l ₁ , l ₂	E ₁	L ₁	L _{H1}	M ₁	F	G	E	L		L _H	M, N
	d ₁ ¹⁾	D ₁	d ₂ ¹⁾	D ₂															
14	5	10	Ø6, Ø7,	22	Ø6, Ø7, Ø8	22	40	23	2	48	40	8	18.5	21.5	4	50	37	6.5	6000
M-14			Ø8, Ø9	25	Ø10, Ø11	25													
			Ø12, Ø14	26	Ø12, Ø14	26													
19	8	16	Ø10, Ø11, Ø12, Ø14	27	Ø12, Ø14,	27	47	25	2	52	42	10	19.0	23.0	4	54	37	8.5	6000
M-19			Ø15, Ø16	30	Ø15, Ø16	29													
			Ø19	32	Ø19	35													
24	12	24	Ø10, Ø11,	26	Ø14, Ø16	32	53	26	2	54	45	9	21.5	23.5	4	56	41	7.5	6000
M-24			Ø12																
			Ø14, Ø15,	32															
			Ø16																
			Ø18, Ø19,	36	Ø19, Ø20	36													
			Ø20																
			Ø24	38	Ø24	40													

¹⁾ Finish bore with tolerance +0.05/-0.1; feather keyway ±0.08

Ordering example:	BoWex® junior 19	d ₁ Ø19	d ₂ Ø14
	Coupling size two-part type or BoWex® junior M-19 three-part type	Finish bore	Finish bore

BoWex® M, I Curved-tooth gear coupling®

Compact and maintenance-free

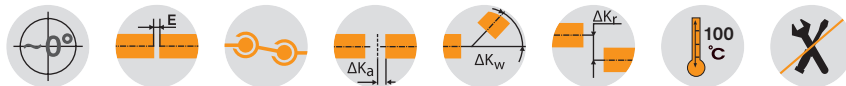
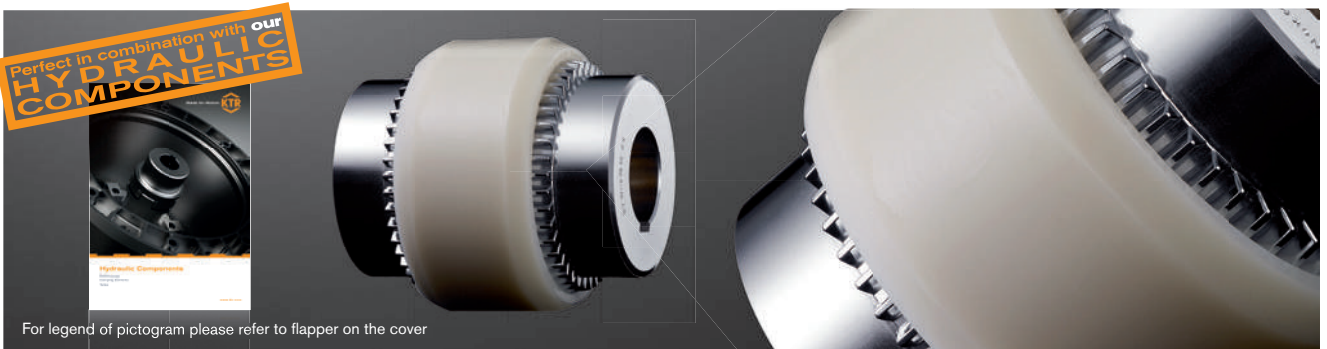

Components

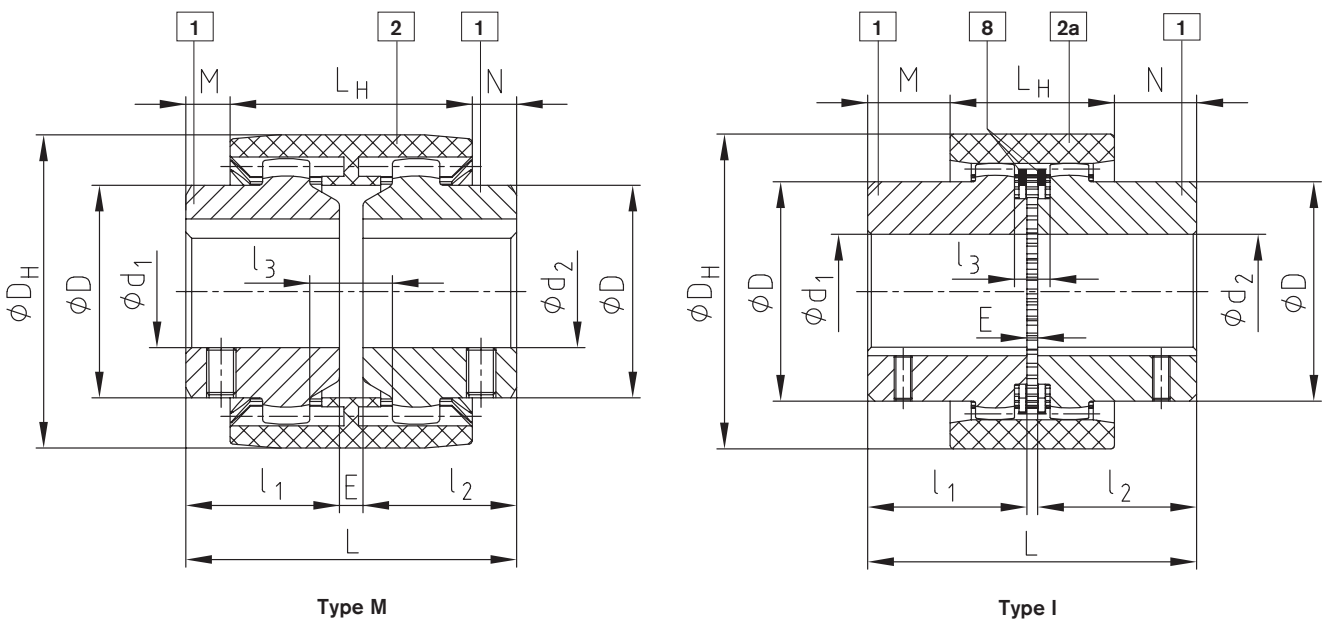

BoWex® type M, type I																								
Size	Torque [Nm]			Finish bore d1, d2		Dimensions [mm]													Weight with max. bore [kg]			Mass moment of inertia J with max. bore [kgcm ²]		
	T _{KN}	T _{K max}	T _{KW}	Pilot bored	Max.	l ₁ , l ₂	E	L	L _H	M, N	l ₃	D	D _H	Tip circle ØD _Z hub	Number of teeth	Hub lengthened max. l ₁ , l ₂	Sleeve	Hub	Total	Sleeve	Hub	Total		
M-14	10	30	5	-	15	23	4	50	37	6.5	10	25	40	33	20	40	0.03	0.07	0.1	0.08	0.09	0.26		
M-19	16	48	8	-	20	25	4	54	37	8.5	10	32	47	39	24	40	0.03	0.1	0.23	0.15	0.16	0.47		
M-24	20	60	10	-	24	26	4	56	41	7.5	14	36	53	45	28	50	0.04	0.14	0.32	0.21	0.36	0.93		
M-28	45	135	23	-	28	40	4	84	46	19	13	44	65	54	34	55	0.08	0.33	0.74	0.65	1.22	3.09		
M-32	60	180	30	-	32	40	4	84	48	18	13	50	75	63	40	55	0.09	0.43	0.95	1.14	2.17	5.48		
M-38	80	240	40	-	38	40	4	84	48	18	13	58	83	69	44	60	0.13	0.55	1.23	1.58	3.55	8.68		
M-42	100	300	50	-	42	42	4	88	50	19	13	65	92	78	50	60	0.14	0.68	1.5	2.32	5.98	14.28		
M-48	140	420	70	-	48	50	4	104	50	27	13	68	95	78	50	60	0.23	0.79	1.81	3.9	7.22	18.34		
M-65	380	1140	190	21	65	55	4	114	68	23	16	96	132	110	42	70	0.55	1.9	4.35	21.2	31.8	84.8		
I-80	700	2100	350	31	90	90	6	186	93	46.5	20	124	178	145	46	-	1.13	5.2	11.53	68.9	150.8	370.5		
I-100	1200	3600	600	38	100	110	8	228	102	63	22	152	210	176	48	-	1.78	9.37	20.52	158.6	401.3	961.2		
I-125	2500	7500	1250	45	125	140	10	290	134	78	30	192	270	225	54	-	3.88	19.44	42.76	562.9	1362.3	3287.5		

Ordering example:	BoWex® M-28	d ₁ Ø20	d ₂ Ø28
	Size and type of coupling	Finish bore H7 keyway to DIN 6885 sheet 1 (JS9)	Finish bore H7 keyway to DIN 6885 sheet 1 (JS9)

BoWex® M...C Curved-tooth gear coupling®

Compact and maintenance-free

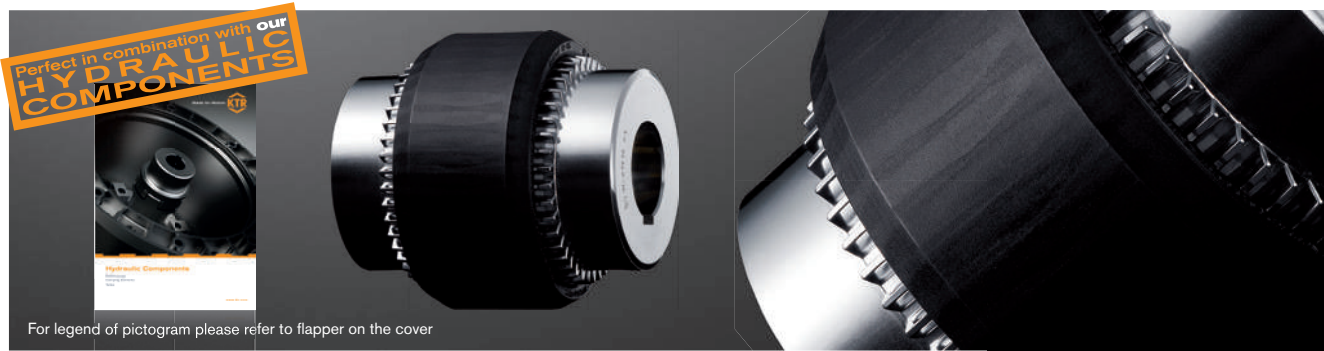

For legend of pictogram please refer to flapper on the cover

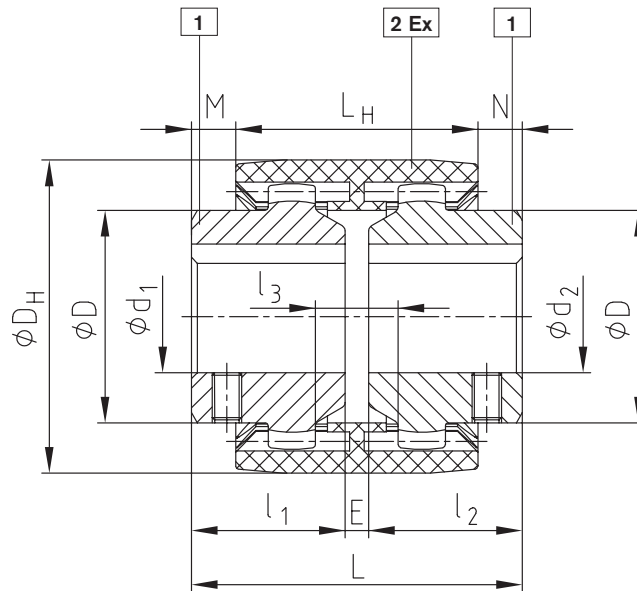
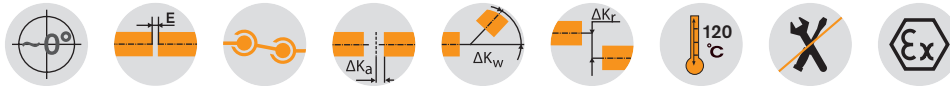

Type M...C

BoWex® Type M...C																								
Size	Torque [Nm]			Finish bore d1, d2		Dimensions [mm]													Weight with max. bore [kg]			Mass moment of inertia J with max. bore [kgcm ²]		
	T _{KN}	T _{K max}	T _{KW}	Pilot bored	Max.	l ₁ , l ₂	E	L	L _H	M, N	l ₃	D	D _H	Tip circle ØDz hub	Number of teeth	Hub lengthened max. l ₁ , l ₂	Sleeve	Hub	Total	Sleeve	Hub	Total		
M-14C	15	45	7,5	-	15	23	4	50	37	6,5	10	25	40	33	20	40	0.03	0.07	0.1	0.08	0.09	0.26		
M-19C	24	72	12	-	20	25	4	54	37	8,5	10	32	47	39	24	40	0.03	0.1	0.23	0.15	0.16	0.47		
M-24C	30	90	15	-	24	26	4	56	41	7,5	14	36	53	45	28	50	0.04	0.14	0.32	0.21	0.36	0.93		
M-28C	70	210	35	-	28	40	4	84	46	19	13	44	65	54	34	55	0.08	0.33	0.74	0.65	1.22	3.09		
M-32C	90	270	45	-	32	40	4	84	48	18	13	50	75	63	40	55	0.09	0.43	0.95	1.14	2.17	5.48		
M-38C	120	360	60	-	38	40	4	84	48	18	13	58	83	69	44	60	0.13	0.55	1.23	1.58	3.55	8.68		
M-48C	200	600	100	-	48	50	4	104	50	27	13	68	95	78	50	60	0.23	0.79	1.81	3.9	7.22	18.34		
M-65C	560	1680	280	21	65	55	4	114	68	23	16	96	132	110	42	70	0.55	1.9	4.35	21.2	31.8	84.8		
M-80C	1000	3000	500	31	90	90	6	186	93	46,5	20	124	178	145	46	-	1.13	5.2	11.53	68.9	150.8	370.5		

Ordering example:	BoWex® M-28C	d ₁ Ø20	d ₂ Ø28
	Size and type of coupling	Finish bore H7 keyway to DIN 6885 sheet 1 (JS9)	Finish bore H7 keyway to DIN 6885 sheet 1 (JS9)

BoWex® AS and Spec.-I Curved-tooth gear coupling®

Compact and maintenance-free

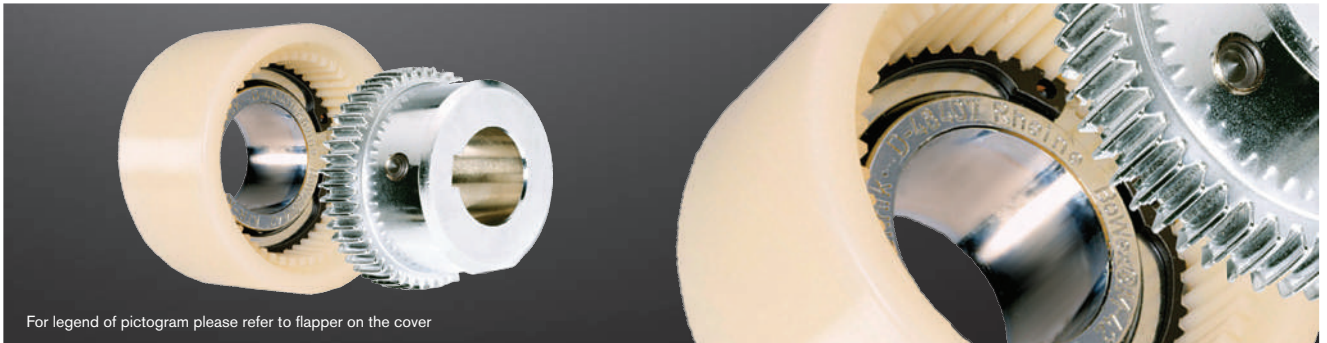

For legend of pictogram please refer to flapper on the cover

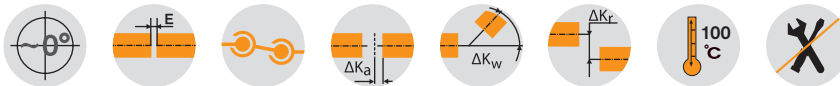

Components

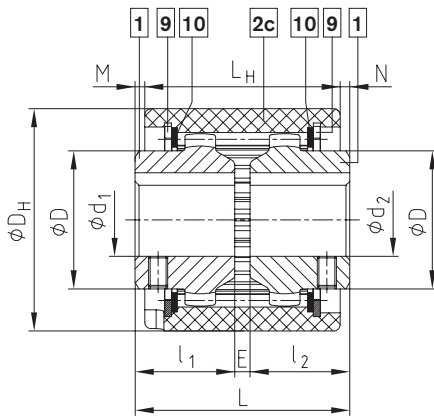

Type AS

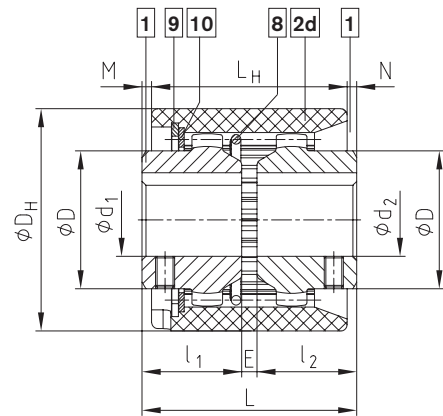

Type Spec.-I

BoWex® Type AS and type Spec.-I

Size	Pilot bore		Finish bore d ₁ , d ₂	Dimensions [mm]									Weight with max. bore [kg]			Mass moment of inertia J with max. bore [kgcm ²]		
	Unbored	Pilot bored		Max.	l ₁ , l ₂	E	L	L _H	M, N	D	D _H	Hub length max. l ₁ , l ₂	Sleeve	Hub	Total	Sleeve	Hub	Total
24	x	-	For finish bores see stock programme	24	26	4	56	51	2.5	36	58	50	0.11	0.14	0.39	0.38	0.36	1.10
28	x	-		28	40	4	84	56	14	44	70	55	0.16	0.33	0.82	1.54	1.22	3.98
32	x	-		32	40	4	84	58	13	50	84	55	0.21	0.43	1.07	2.75	2.17	7.09
45	x	-		45	42	4	88	60	14	65	100	60	0.27	0.63	1.53	5.49	5.66	16.81
65	-	21		65	55	4	114	84	15	96	140	70	0.84	2.10	5.00	29.83	43.96	117.8
80	-	31		90	90	6	186	93	46.5	124	178	-	1.30	5.20	11.70	83.20	150.8	384.8
100	-	38		100	110	8	228	102	63	152	210	-	2.05	9.40	20.80	184.4	401.3	987.0
125	-	45	125	140	10	290	134	78	192	270	-	4.32	19.44	43.10	620.0	1362.3	3344.6	

For performance data see page 88.

Ordering example:	BoWex® 32 AS	d ₁ Ø32	d ₂ Ø32
	Size and type of coupling AS or Spec.-I	Finish bore H7 keyway to DIN 6885 sheet 1 (JS9)	Finish bore H7 keyway to DIN 6885 sheet 1 (JS9)

BoWex® SG, SSR and Spec.-I/CD Curved-tooth gear coupling®

Type with dust protection



For legend of pictogram please refer to flapper on the cover

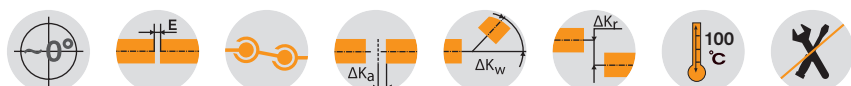

BoWex® Type SG with dust protection circlips												
Size	Pilot bore		Finish bore		Dimensions [mm]							
	Unbored	Pilot bored	Min.	Max.	l_1, l_2	E	L	L_H	M, N	D	D_H	Hub length. max. l_1, l_2
24 SG	x	-	10	24	36	4	76	51	12.5	36	58	50
28 SG	x	-	10	28	40	4	84	56	14	44	70	55
32 SG	x	-	12	32	40	4	84	58	13	50	84	55
45 SG	x	-	20	45	42	4	88	60	14	65	100	60
65 SG	-	21	30	65	70	4	144	84	30	96	140	-
80 SG	-	31	35	90	90	6	186	93	46.5	122	175	-
100 SG	-	38	40	100	110	8	228	102	63	150	210	-
125 SG	-	45	50	125	140	10	290	134	78	190	270	-

Setscrews with finish bored hubs only.

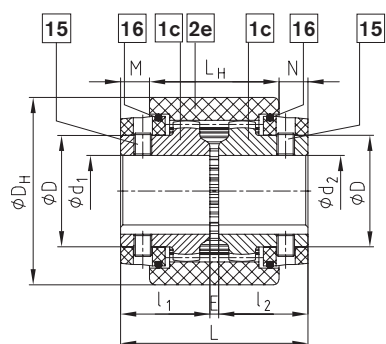

BoWex® Type SSR with Seeger circlips												
Size	Pilot bore		Finish bore		Dimensions [mm]							
	Unbored	Pilot bored	Min.	Max.	l_1, l_2	E	L	L_H	M, N	D	D_H	Hub length. max. l_1, l_2
24 SSR	x	-	10	22	26	4	56	51	2.5	35	58	50
28 SSR	x	-	10	26	40	4	84	56	14	42	70	55
32 SSR	x	-	12	30	40	4	84	58	13	48	84	55
45 SSR	x	-	20	42	42	4	88	60	14	63	100	60
65 SSR	-	21	30	65	55	4	114	84	15	95	140	70
80 SSR	-	31	35	90	90	6	186	93	46.5	120	175	-
100 SSR	-	38	40	100	110	8	228	102	63	150	210	-
125 SSR	-	45	50	125	140	10	290	134	78	190	270	-

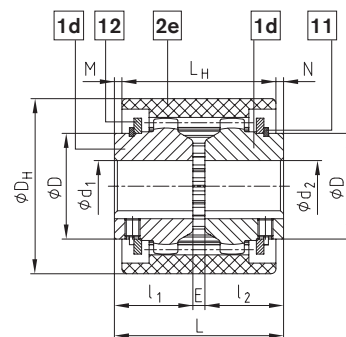

BoWex® Type Spec.-I/CD															
Size	Pilot bore		Finish bore		Dimensions [mm]										
	Unbored	Pilot bored	Min.	Max.	L	L_1	L_H	E	E_1	l_2	l_1	D_H	D	M	N
24 CD	x	-	10	24	70	73.5	51	4	9.0	26	40	58	36	20	2.5
28 CD	x	-	10	28	94.5	98	56	4	8.5	40	50.5	70	44	28	14
32 CD	x	-	12	32	94.5	-	58	4	8.5	40	50.5	84	50	27	13
45 CD	x	-	20	45	101.5	-	60	4	8.5	42	55.5	100	65	32	14
65 CD	-	21	30	65	123	-	84	4	10	55	64	140	96	28.5	15
80 CD	-	31	35	90	179	-	93	6	13	90	83	178	124	44	46.5

Please order dimension sheet for type Spec.-I/CDB with safety pins.
For performance data see page 88.

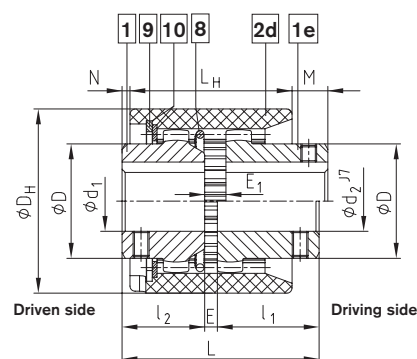

Ordering example:

BoWex® 45 SG	$d_1 \text{ } \varnothing 22$	$d_2 \text{ } \varnothing 40$
Size and type of coupling SG, SSR or Spec.-I/CD	Finish bore H7 keyway to DIN 6885 sheet 1 (JS9)	Finish bore H7 keyway to DIN 6885 sheet 1 (JS9)

BoWex® SD/SD-D Curved-tooth gear coupling®

Shiftable coupling (at standstill)



For legend of pictogram please refer to flapper on the cover

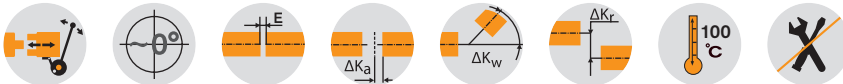

BoWex® Type SD																							
Size	Pilot bore		Finish bore d ₁ , d ₂			Dimensions [mm]												Weight with max. bore [kg]		Mass moment of inertia J with max. bore [kgcm ²]		Shifting force [N]	
	Unbo- red	Pilot bored	d ₁	d ₁ max.	d ₂ max.	E	l ₁	l ₂	L	L _H	l ₃	M	W	N	D	D _H	D _A	Shifting hub with sleeve	Driving hub	Shifting hub with sleeve	Driving hub		
24 SD	x	-	For finish bores see stock programme on page 88	24	24	4	26	50	80	52	31	10	19	18	36	58	78	1.08	0.14	8.23	0.36	140	
28 SD	x	-		28	28	4	40	55	99	57	33	21.5	21.5	20.5	44	70	88	1.50	0.33	15.62	1.22	180	
32 SD	x	-		32	32	4	40	55	99	58	33	20.5	21.5	20.5	50	84	100	1.85	0.43	22.87	2.17	180	
45 SD	x	-		45	45	4	42	60	106	63	37	21.5	22.5	21.5	65	100	125	2.56	0.68	2.30	46.07	5.66	250
				48			50		114			29.5											
65 SD	-	21		65	65	4	55	70	129	77	37	28	28	25	24	95	140	156	5.07	2.30	158.99	43.96	350
80 SD	-	31		90	90	6	90	90	186	96	47	56	35	34	124	175	195	10.60	5.20	523.7	150.8	350	
100 SD	-	38		100	100	8	110	110	228	113	55	72	43	43	152	210	235	18.87	9.37	1350	401.3	400	
125 SD	-	45		125	125	10	140	140	290	149	70	89	52	52	192	270	298	40.40	9.44	4919	1362.3	450	

Connection dimensions of BoWex® SD shifting ring (comp. 17) for mounting of: slip ring SD1 (s. catalogue on p. 89), shifting disk etc.

Size	Dimensions [mm]			
	L ₁	L ₂	z x G	s
24 SD	48	58	4 x M6	2
28 SD	48	58	4 x M6	2
32 SD	64	75	4 x M6	2
45 SD	75	90	4 x M8	2
65 SD	100	114	4 x M8	2
80 SD	130	145	4 x M8	3
100 SD	180	196	6 x M10	4
125 SD	220	236	6 x M10	4

Performance data/torques see type M (on page 88), max. circumferential speed v = 20 m/s, referring to ØD_A
Other sizes on request

Ordering example:	BoWex® 32 SD	d ₁ Ø32	d ₂ Ø32
	Size and type of coupling	Finish bore H7 keyway to DIN 6885 sheet 1 (JS9)	Finish bore H7 keyway to DIN 6885 sheet 1 (JS9)

Components

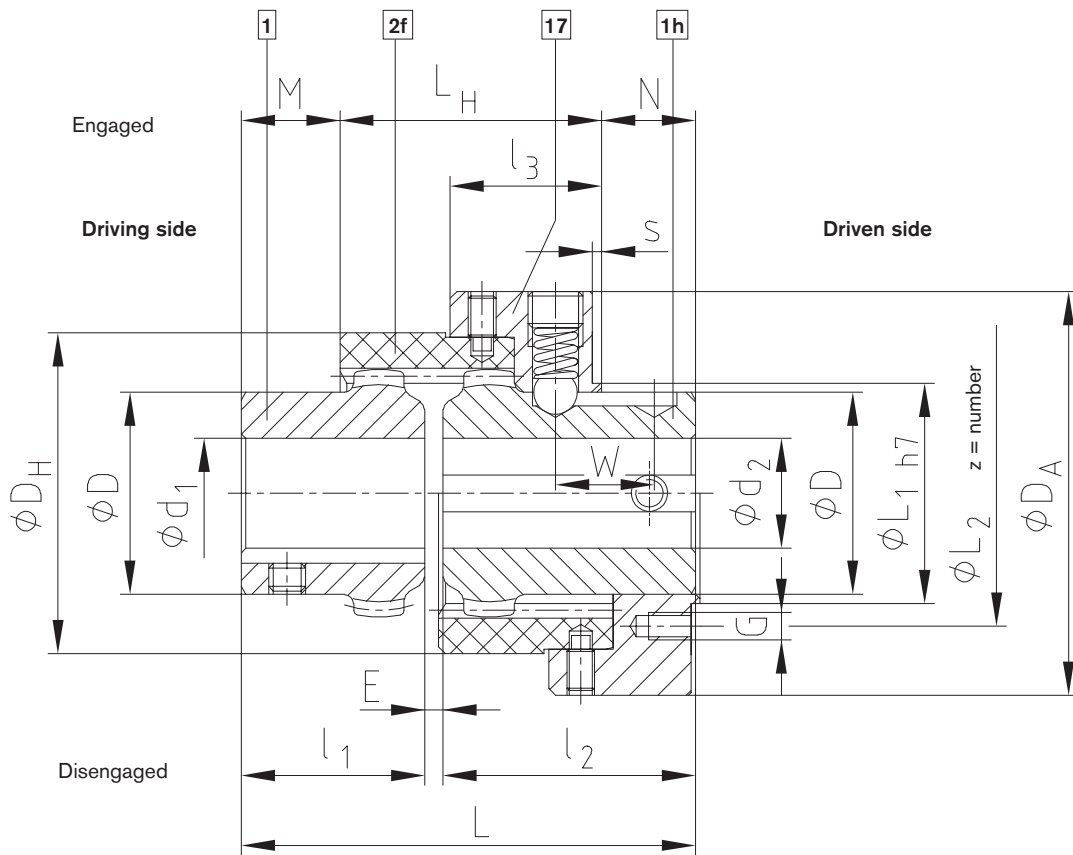

BoWex® SD

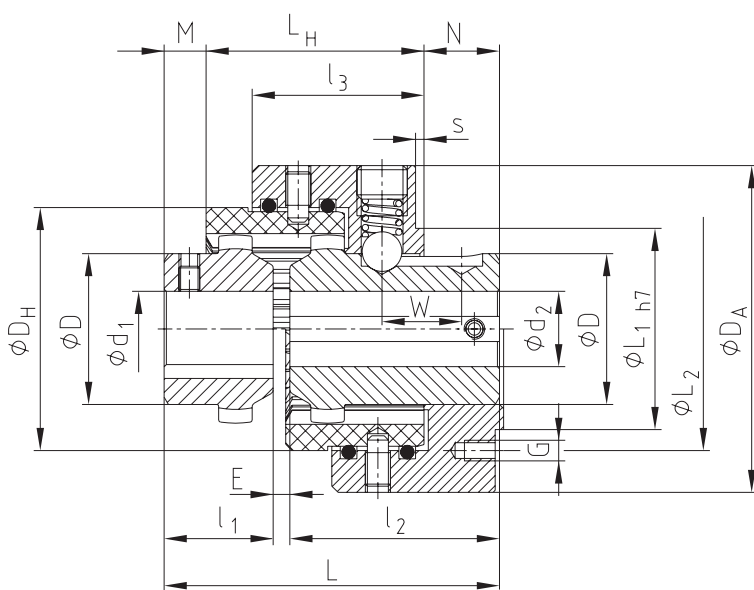

BoWex® SD-D

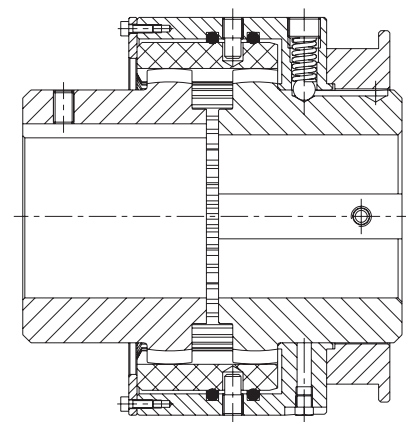

BoWex® SD-D3

GEARex®

BoWex® SD1 Curved-tooth gear coupling®

Shiftable coupling with shiftable linkage (at standstill)

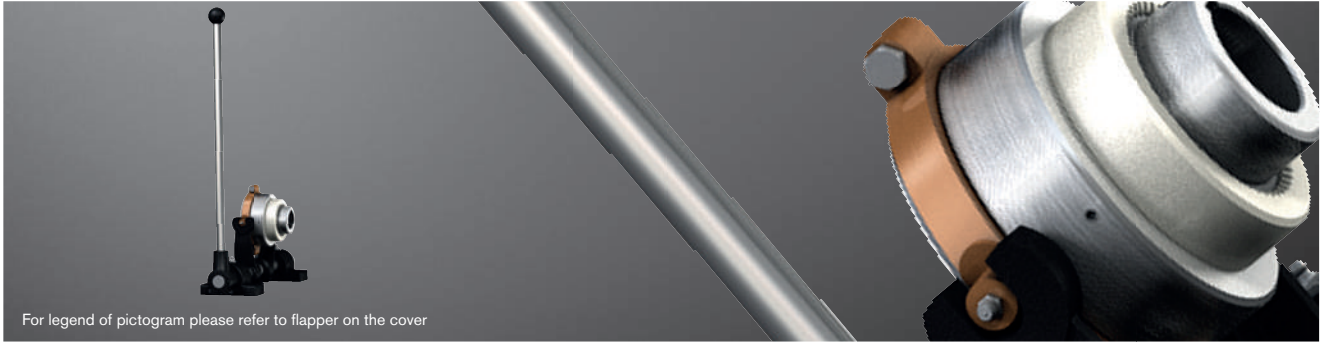

For legend of pictogram please refer to flapper on the cover

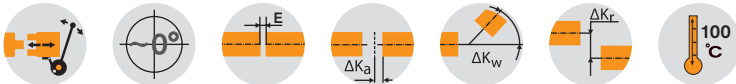

BoWex® Type SD1 and slip ring																					
Size	Finish bore			Dimensions [mm]																	Shifting force [N]
	d1	d1 max.	d2 max.	E	l1	l2	L	LG	l4	l5	M	W	t	D	DH	DA	D1	D2 ±0.1 (keyway)	D5	n ±0,1 (keyway)	
24 SD1		24	24	4	26	50	80	67	11	46	10	19	16	36	58	78	45	70.5	78	12.5	140
28 SD1		28	28	4	40	55	99	72	11	48	21.5	21.5	16	44	70	88	45	70.5	78	12.5	180
32 SD1		32	32	4	40	55	99	78	13.5	53	20.5	21.5	21	50	84	100	60	89.5	100	17.5	180
45 SD1	For finish bores see stock programme on page 86	45		4	42		106				21.5										
		48	45		50	60	114	84	14	58	29.5	22.5	22	65	100	125	70	112.5	125	18	250
65 SD1		65	65	4	55	70	129	103	16	61	26	25	25	96	140	156	96	130.5	145	20.5	350
80 SD1		90	90	6	90	90	186	124	18.5	75	56	35	29	124	175	195	125	164.5	182	25.5	350
100 SD1		100	100	8	110	110	228	152	28	94	72	43	39	152	210	235	174	210.5	230	30.5	400
125 SD1		125	125	10	140	140	290	193	30.5	114	89	52	44	192	270	298	214	250.5	275	35.5	450

BoWex® Type SD1 - Shiftable linkage																					
Size	Shiftable linkage size	Slip ring size	Dimensions [mm]																Dimensions with m1 max.		
			a	b	c	d	d3	d4	e	F	g1	L2	L3	m	m1 min.	m1 max.	A	B	m3	m4	m5
24 SD1	1	1.1																			
28 SD1	1	1.1	110	50	18	20	11	16	30	70	55	320	400	75	180	190	90	114		55	16
32 SD1	2	2.2				25				97.5	60	430	450		240	270	111	151	20	80	34
45 SD1	3	3.3	140			30		20	40	120		490	600	100	280	310	140	180		90	44
65 SD1	3	4.4		60	25						70						170	210			
80 SD1	4	5.5				35	13.5			50	147.5				321	365	200	244		100	54
100 SD1	5	6.6	160			40		30	50 ¹⁾	190	80	630	1085	120	365	410	250	300	30	110	62
125 SD1	5	7.7													-		300	350			

¹⁾ = With a continuous base plate dimension „e“ has to be increased by at least 10 mm. The brackets of the driving and driven side have to be adjusted accordingly. Also available as type SD-D. Other sizes on request.

Performance data/torques see type M (on page 88), max. circumferential speed $v = 20$ m/s, referring to $\varnothing D_A$

Ordering example:	BoWex® 65 SD1	d1 Ø32	d2 Ø32	4.4	3
	Size and type of coupling	Finish bore H7 keyway to DIN 6885 sheet 1 (JS9)		Slip ring Size	Shiftable linkage Size

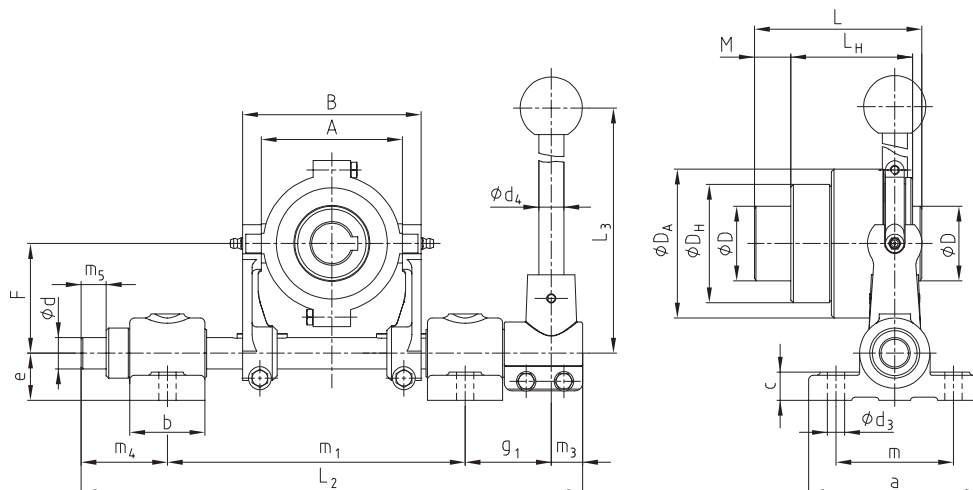
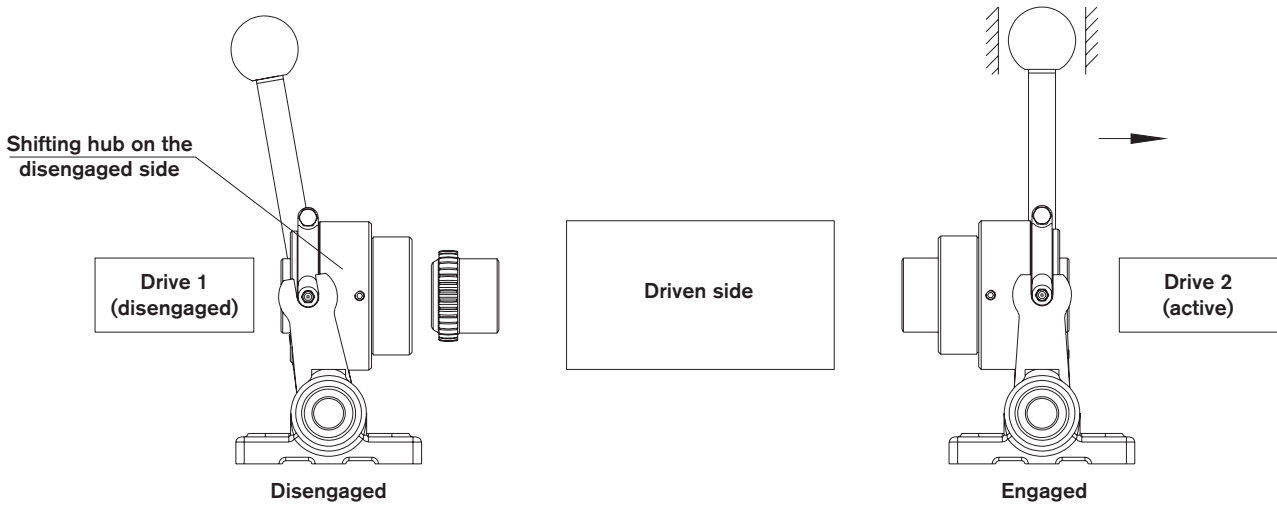
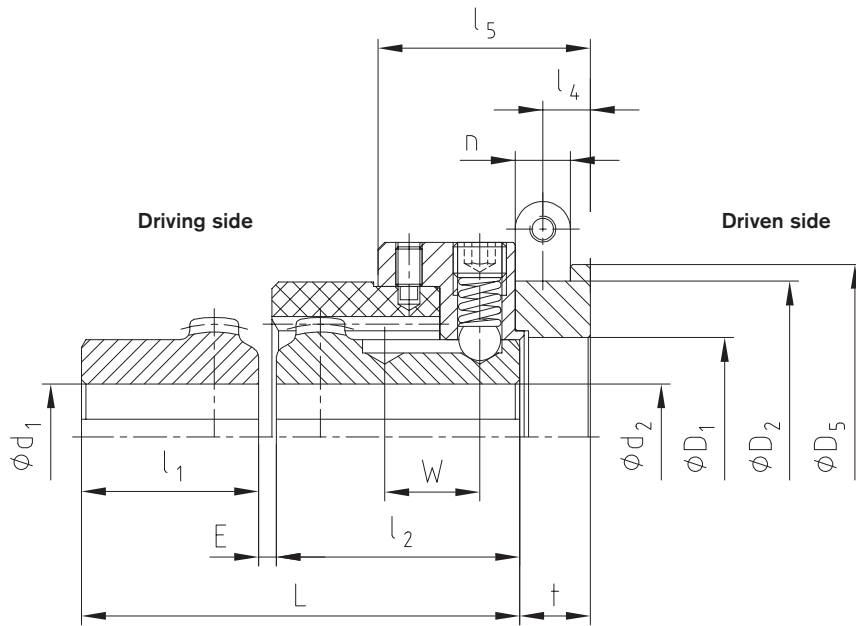

BoWex® GT Curved-tooth gear coupling®

Split CFK sleeve for high power density



For legend of pictogram please refer to flapper on the cover

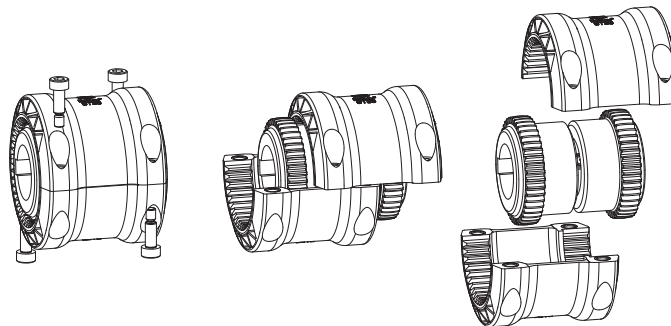
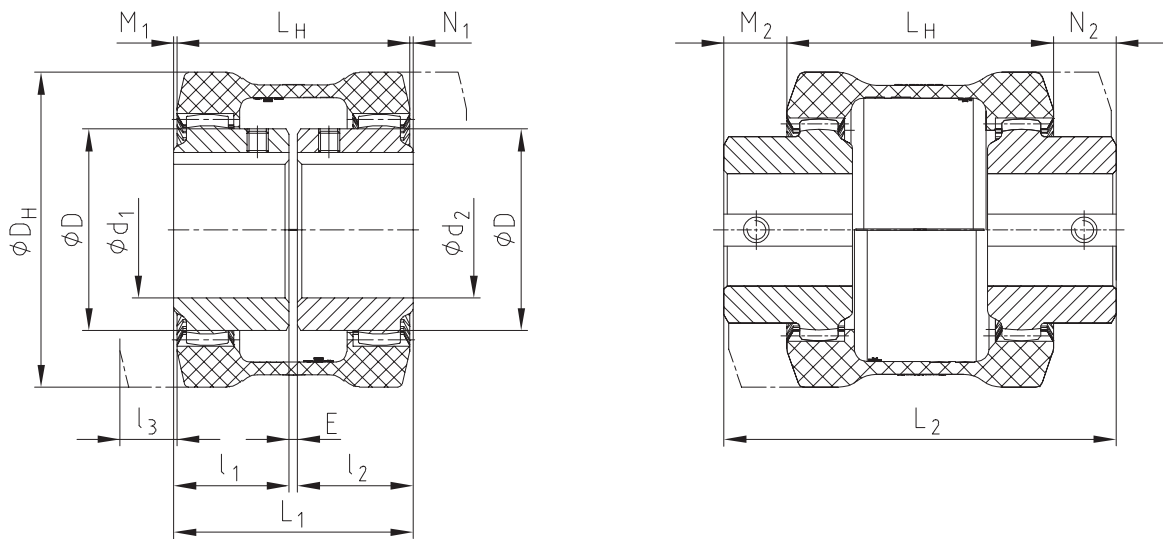
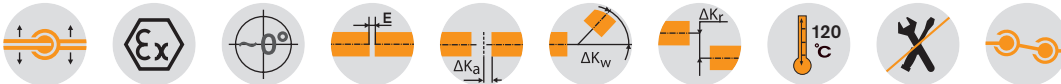

BoWex® Type GT with split sleeve

Size	Torque [Nm]			Finish bore d_{max}		Dimensions [mm]										Weight with max. bore [kg]			Mass moment of inertia J with max. bore [kgcm ²]			
	T _{KN}	T _{K max}	T _{KW}	d ₁	d ₂	D	D _H	L _H	l ₁	l ₂	l ₃	E	L ₁	L ₂	M ₁ , N ₁	M ₂ , N ₂	Sleeve	Hub	Total	Sleeve	Hub	Total
28	70	210	35	28	28	44	80	80	40	40	15	4	84	124	2	22	0.158	0.22	0.702	1.77	1.22	4.21
38	120	360	60	38	38	58	98	83	40	40	18	4	84	122	0.5	19.5	0.25	0.45	1.15	4.43	3.36	11.15
48	200	600	100	48	48	68	110	106	50	50	21	4	104	160	0	28	0.33	0.67	1.68	7.39	6.11	19.61
65	560	1680	280	65	65	96	150	111	55	55	27	4	114	160	1.5	24.5	0.69	1.54	3.77	28.9	31.80	92.5

l₃ = Drop-out center dimension required

Ordering example:	BoWex® GT-28	d ₁ Ø20	d ₂ Ø28
		Size and type of coupling	Finish bore H7 keyway to DIN 6885 sheet 1 (JS9)

BoWex® ZR Curved-tooth gear coupling®

Bridging larger shaft distances

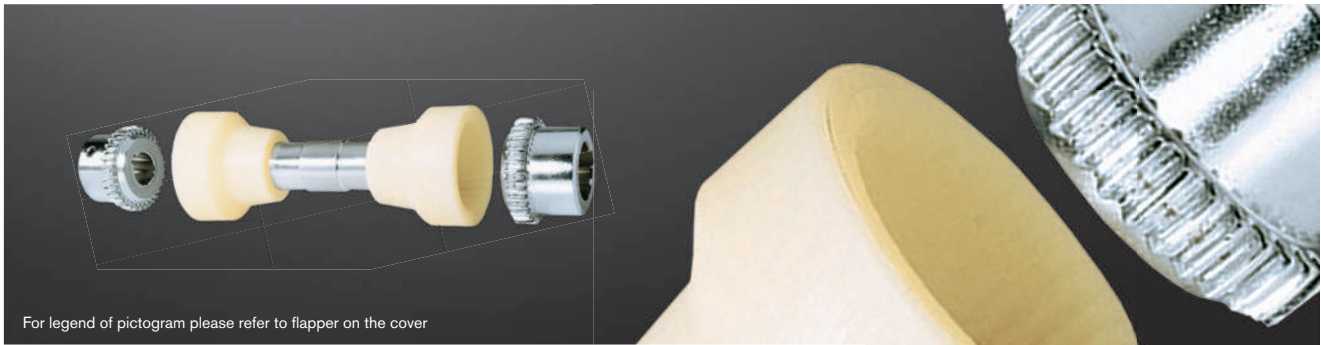

For legend of pictogram please refer to flapper on the cover

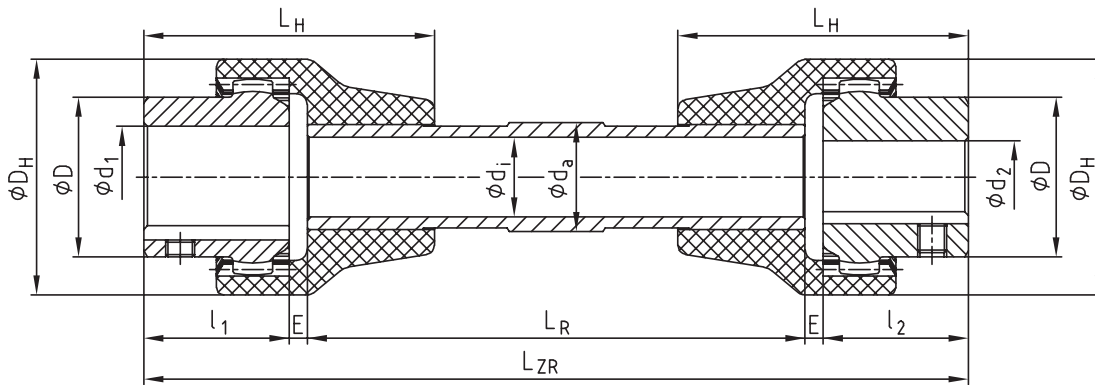
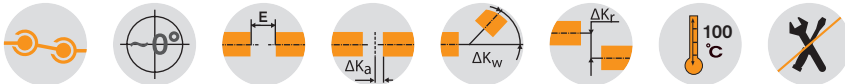

BoWex® Type ZR															
Size	Pilot bore	Finish bore	Dimensions [mm]										Torque [Nm]		
		d1 max. d2 max.	l1, l2	Hub length. max. l1, l2	LH	E	LZR tot.	LR	D	DH	di	da	TKN	TK max	TKW
14	-	14	23	40	40	3	According to customer specification		25	40	21	25	10	20	5
28	-	28	40	55	60	3			44	66	30	26	45	90	23
42	-	42	42	60	85	3			65	95	40	50	100	200	50
48	-	48	50	60	85	3			68	95	40	50	140	280	70

BoWex® ZR couplings are available up to a length of 2000 mm for serial applications only ($n_{max.} = 1000$ rpm)

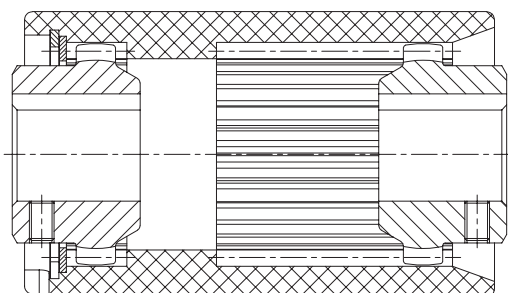

Type Spec.-I with a long PA-sleeve

- BoWex® Spec.-I with lengthened sleeve on request
- Bridging larger shaft distances
- Axial shifting of driving and driven shaft at standstill
- Maintenance-free
- Compensating for larger displacements
- Axial plug-in
- Application range from -25 °C to +100 °C

BoWex® HEW Compact Curved-tooth gear coupling®

Compensating for large displacements, very compact design

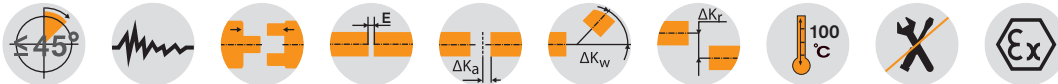
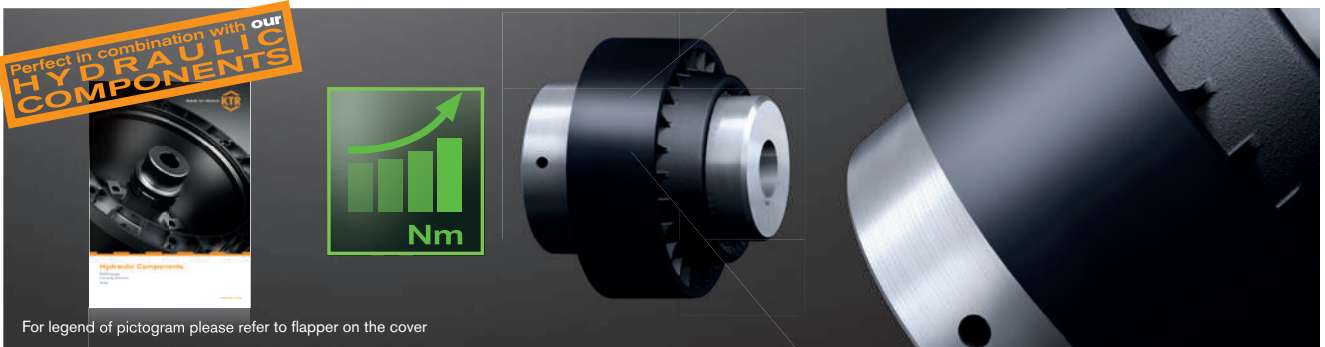

BoWex® Type HEW Compact																			
Size	Max. finish bore d		Dimensions [mm]												Weight with pilot bored coupling [kg]	Mass moment of inertia with pilot bored coupling J ₁ [kgm ²]	Mass moment of inertia with pilot bored coupling J ₂ [kgm ²]		
	d ₁	d ₂	D ₁	D ₂	D ₄	l ₁	l ₂	l ₃	l ₄	E	L	L ₁	D ₅	D ₃				z	M
42-130	42	42	90	65	131	42	42	45	37	34	118	98	65	78	6	M6	3.4	0.003	0.001
65-180	65	65	130	96	180	60	55	55	47	30	145	122	85	110	8	M10	9	0.014	0.006
80-225	75	90	145	124	225	70	90	77	51	50	210	158	100	120	10	M12	18.9	0.035	0.029
130-305	100	100	200	152	305	90	110	90	73	58	258	187	170	175	16	M12	40.2	0.152	0.087
125-365	125	125	235	192	365	120	140	105	90	68	328	240	170	205	12	M16	75	0.36	0.26

Technical data												
Coupling size	Elastomer hardness [Shore A]	Torque [Nm]			Perm. speed n _{max.} [rpm]	Perm. damping power			Dynamic torsion spring stiffness C _T dyn. [Nm/rad]	Relative damping ψ	Resonance factor V _R ≈ 2·Π/ψ	Radial spring stiffness C _r [N/mm]
		T _K	T _K max	with 10 Hz T _{KW}		PKW						
						60 °C	80 °C	90 °C				
BoWex® 42 HEW Compact	T50	200	400	50	7300	30	18	12	780	0.8	7.9	178
	T65	270	540	68					2400	1.2	5.2	600
	T70	320	640	80					2900	1.2	5.2	710
BoWex® 65 HEW Compact	T50	550	1100	138	5500	55	33	22	2850	0.8	7.9	379
	T65	740	1500	185					7800	1.2	5.2	955
	T70	860	1700	215					9500	1.2	5.2	1240
BoWex® 80 HEW Compact	T50	1250	2500	313	4400	90	54	36	5000	0.8	7.9	420
	T65	1600	3200	400					13000	1.2	5.2	1090
	T70	1900	3800	475					16500	1.2	5.2	1450
BoWex® 100 HEW Compact	T50	2750	5500	688	3200	150	90	60	17000	0.8	7.9	760
	T65	3900	7800	975					44000	1.2	5.2	1850
	T70	4500	9000	1125					50000	1.2	5.2	2250
BoWex® 125 HEW Compact	T50	5500	11000	1375	2900	220	132	88	25000	0.8	7.9	750
	T65	7500	15000	1875					62000	1.2	5.2	1930
	T70	8400	16800	2100					70000	1.2	5.2	2300

■ = Years of experience with applications at customer sites and additional test series in the KTR test field in Rheine enabled us to determine potentials allowing for an increase of the rated torques with some sizes of this series.

Ordering example:	BoWex® 65 HEW Compact	T50	d ₁ Ø40	d ₂ Ø65
	Size and type of coupling	Elastomer hardness	Finish bore H7 keyway to DIN 6885 sheet 1 (JS9)	Finish bore H7 keyway to DIN 6885 sheet 1 (JS9)

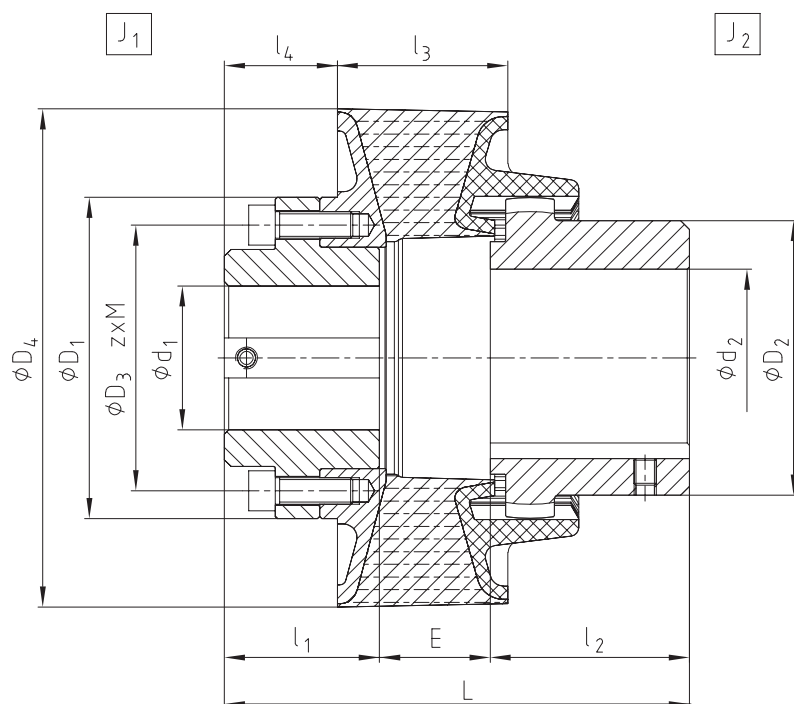

BoWex® HEW Compact with reduced hub

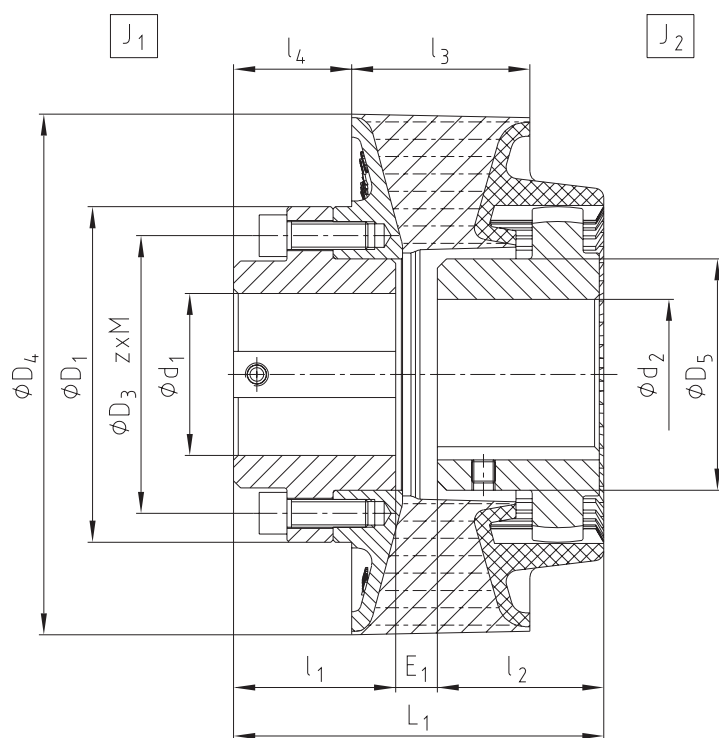

BoWex® M Curved-tooth gear coupling®

Made of corrosion-resistant materials



For legend of pictogram please refer to flapper on the cover



BoWex® junior plug-in coupling (two-part) and BoWex® junior M (three-part)

Size	Finish bore				Dimensions [mm]									
	Hub Component 1b		Plug-in sleeve Component 2b		D _H	l ₁ , l ₂	E ₁	E	L _{H1}	L _H	L ₁	L	M ₁	M, N
	d ₁	D ₁	d ₂	D ₂										
14 M-14	Ø6, Ø7, Ø8, Ø9	22	Ø8	22	40	23	2	4	40	37	48	50	8	6.5
	Ø10, Ø11	25	Ø10, Ø11	25										
19 M-19	Ø12, Ø14	26	Ø12, Ø14	26	48	25	2	4	42	37	52	54	10	8.5
	Ø12, Ø14	27	Ø14, Ø15	29										
	Ø16	30	Ø19	35										
24 M-24	Ø10, Ø11, Ø12	26	Ø14, Ø16	32	53	26	2	4	45	41	54	56	9	7.5
	Ø14, Ø15, Ø16	32	Ø19, Ø20	36										
	Ø18, Ø19, Ø20	36	Ø24	40										

BoWex® Type M

Size	Finish bore d ₁ max. d ₂ max.	Dimensions [mm]						
		D _H	D	l ₁ , l ₂	E	L _H	L	M, N
M-24	24	53	36	26	4	41	56	7.5
M-38	38	83	58	40	4	48	84	18
M-48	48	95	68	50	4	50	104	27

Other coupling sizes: M-24C, M-38C, M-48C on request. Setscrews with BoWex® junior coupling are made of V4A as a standard. For performance data see page 88.

Applications:

Food industry, print and paper industry, textile industry, sewage technology, wash-mobiles, chemical and pharmaceutical industry, offshore units, etc. For use in aggressive environment (air, water, chemicals, etc.).

Ordering
example:

BoWex® M-24 V4A

d₁ Ø20

d₂ Ø24

Size and type of coupling

Finish bore H7
keyway to DIN 6885 sheet 1 (JS9)

Finish bore H7
keyway to DIN 6885 sheet 1 (JS9)

Type junior plug-in coupling (two-part)

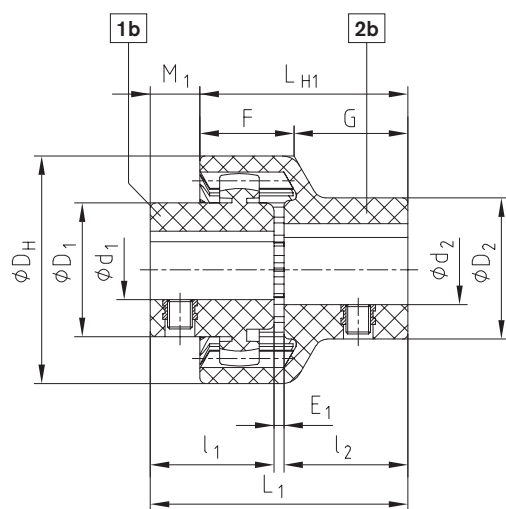

Type junior M coupling (three-part)

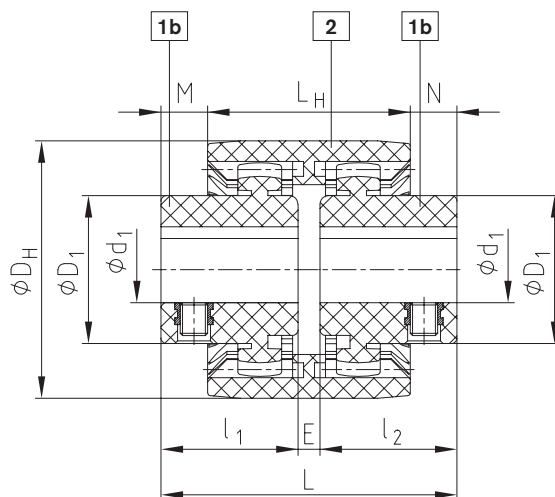

Type M (V4A)

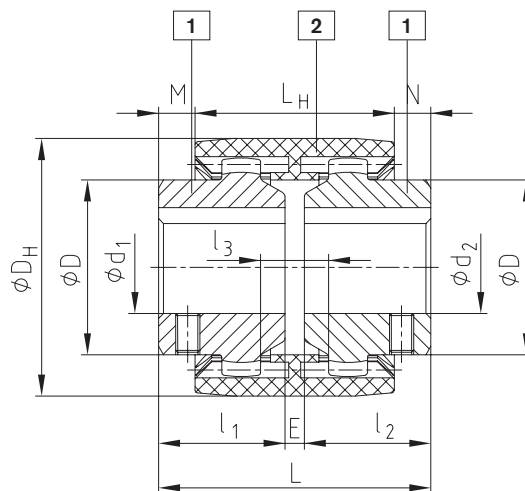

BoWex® Curved-tooth gear coupling®

Taper bores

BoWex® with taper bore

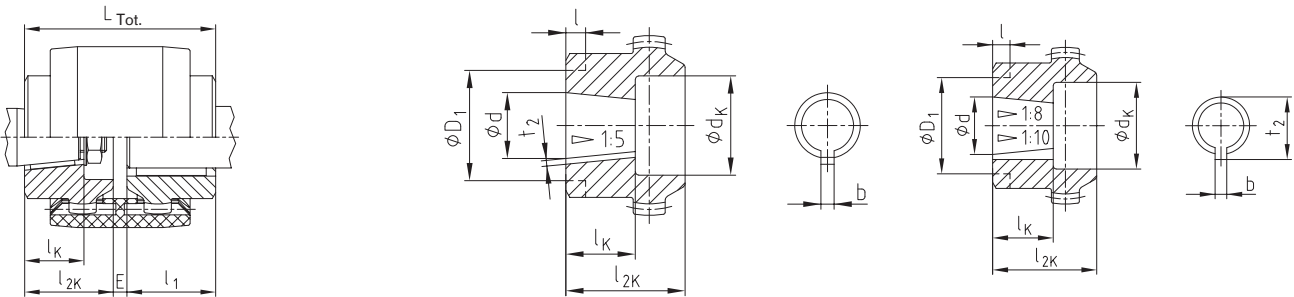

$$L_{Tot} = l_1 + E + l_{2K}$$

see stock programme on page 90

Taper bores 1:5																						
Dimensions [mm]					Counterbore d _K and hub length l _{2K} [mm] Recess on hub collar D ₁ x l [mm]																	
Code	Details of bores				14		19		24		28		32		38		42		48		65	
	d ^{+0.05}	b ^{J59}	t ₂ ^{+0.1}	l _K	d _K	l _{2K}	d _K	l _{2K}	d _K	l _{2K}	d _K	l _{2K}	d _K	l _{2K}	d _K	l _{2K}	d _K	l _{2K}	d _K	l _{2K}	d _K	l _{2K}
A-10	9.85	2	1.0	11.5	18	23	18	25	25	26	25	26	25	26	25	26						
B-17	16.85	3	1.8	18.5			30 x 7	30 x 7	30 x 7	30 x 5					30 x 5							
C-20	19.85	4	2.2	21.5					28	36	36	40	36	40	36	40	45	42	45	42	45	50
Cs-22	21.95	3	1.8	21.5					28	36	36	40	36	40	36	40	45	42	45	42		
D-25	24.85	5	2.9	26.5							36	40	36	40	36	40	45	42	45	42	45	50
E-30	29.85	6	2.6	31.5											45	55	45	55	45	55	45	55
F-35	34.85	6	2.6	36.5															52	60	55	60
G-40	39.85	6	2.6	41.5															52	60	65	70

Taper bores 1:8																						
Dimensions [mm]					Counterbore d _K and hub length l _{2K} [mm] Recess on hub collar D ₁ x l [mm]																	
Code	Details of bores				14		19		24		28		32		38		42		48		65	
	d ^{+0.05}	b ^{J59}	t ₂ ^{+0.1}	l _K	d _K	l _{2K}	d _K	l _{2K}	d _K	l _{2K}	d _K	l _{2K}	d _K	l _{2K}	d _K	l _{2K}	d _K	l _{2K}	d _K	l _{2K}	d _K	l _{2K}
N/1	9.7 ± 0.015	2.4 ^{+0.05}	10.85	17	18	26	18	25	25	26	25	30	25	30	25	30						
N/1c	11.6	3 ^{J59}	12.90	16.5	18	23			25	26	25	30										
N/1e	13	2.4 ^{+0.05}	13.80	21					25	30	25	30			25	30						
N/1d	14	3 ^{J59}	15.50	17.5	20	23	25	30	28	30	28	30	28	40								
N/2	17.287	3.2 ^{+0.05}	18.24	24					28	35	36	40	36	40	36	40	45	42	45	42	45	50
N/2a	17.287	4 ^{J59}	18.94	24					28	35	36	40	36	40	36	40	45	42	45	42	45	50
N/2b	17.287	3 ^{J59}	18.34	24					28	35					36	40	45	42	45	42		
N/3	22.002	4 ^{J59}	23.40	28							36	40	36	40	36	40	45	42	45	42	45	50
N/4	25.463	4.78 ^{+0.05}	27.83	36							36	50	36	50	36	50	45	50	45	50	45	62
N/4b	25.463	5 ^{J59}	28.23	36													58 x 10	58 x 10				
N/4a	27	4.78 ^{+0.05}	28.80	32.5							36	50			36	50						
N/4g	28.45	6 ^{J59}	29.32	38.5											36	60	45	60	45	60		
N/5	33.176	6.38 ^{+0.05}	35.39	44											45	60	45	60	45	60	45	62
N/5a	33.176	7 ^{J59}	35.39	44													45	60	45	60	45	62

Taper bores 1:10																						
Dimensions [mm]					Counterbore d _K and hub length l _{2K} [mm]																	
Code	Details of bores				14		19		24		28		32		38		42		48		65	
	d ^{+0.05}	b ^{J59}	t ₂ ^{+0.1}	l _K	d _K	l _{2K}	d _K	l _{2K}	d _K	l _{2K}	d _K	l _{2K}	d _K	l _{2K}	d _K	l _{2K}	d _K	l _{2K}	d _K	l _{2K}	d _K	l _{2K}
CX-20	19.85	5	22.08	32							36	50			36	50	45	50	45	50		
DX-25	24.95	6	26.68	45									36	50			45	60	45	60	45	60
EX-30	29.75	8	31.88	50													45	60	45	60	45	70

Spline hubs and inch bores

BoWex® spline hubs – basic programme

Spline hub (N)

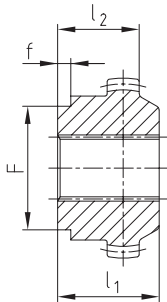

Clamping hub (K)

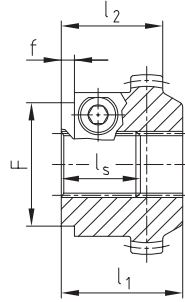

If it is not possible to fasten the hubs of pump shafts with involute spline by means of an end plate and a screw, we recommend to use our spline clamping hub.

Radial clamping ensures a backlash-free tight fit on the pump shaft.

Spline and clamping hubs to DIN 5480

Size	Dimensions [mm]							Order designation specify coupling size
	Type	Spline size	l ₁	l ₂	l _S	F	f	
42	N	25x1.25x18	42	-	-	-	-	P000205
	K	25x1.25x18	42	-	-	-	-	P500202
48	K	30x2x14	42	-	-	60	6	P500203
	N	30x2x14	50	-	-	60	6	P000206
	K	30x2x14	50	-	-	60	6	P500203
65	N	35x2x16	55	-	-	60	6	P000303
	K	35x2x16	60	-	-	60	6	P500301
	N	40x2x18	55	-	-	78	6	P000304
65	K	40x2x18	60	-	-	78	6	P500302
	K	45x2x21	55	-	-	78	6	P500401

Spline and clamping hubs to ANSI B92.1

Size	Dimensions [mm]							Order designation specify coupling size
	Type	Spline size	l ₁	l ₂	l _S	F	f	
42	K	PH-S 5/8"	42	-	-	-	-	P558101
	K	16/32DP, z=9	-	35	-	-	-	P559101
42	K	PI-S 3/4"	-	35	-	-	-	P559101
	K	16/32DP, z=11	-	35	-	-	-	P559101
48	K	PB-S 7/8"	42	-	-	60	3	P567101
	K	16/32DP, z=13	-	-	-	60	3	P567101
48	K	PB-BS 1"	42	-	27	50	6	P660201
	K	16/32DP, z=15	-	-	27	50	6	P660201
48	K	PA-S 3/8"	50	-	45	52	7	P663301
	K	16/32DP, z=21	-	-	45	52	7	P663301
65	K	PA-S 3/8"	55	-	48	52	5	P663301
	K	16/32DP, z=21	-	-	48	52	5	P663301
65	K	PC-S 1 1/4"	55	-	44	52	5	P656201
	K	12/24DP, z=14	-	-	44	52	5	P656201

Inch bores – see stock programme on page 86

Bore and keyway acc. to ANSI/AGMA 9002-C14 Bore (clearance fit) Keyway (commercial class fit)						Bore and keyway acc. to ANSI/AGMA 9002-C14 Bore (clearance fit) Keyway (commercial class fit)					
KTR Code	Bore Ø [Inch]	Width of keyway [Inch]	Bore Ø [mm]	Width of keyway [mm]	Keyway depth/Tolerance +0.381 [mm]	KTR Code	Bore Ø [Inch]	Width of keyway [Inch]	Bore Ø [mm]	Width of keyway [mm]	Keyway depth/Tolerance +0.381 [mm]
Tb	3/8	1/8	9.525 ^{+0.0254}	3.175 ^{+0.05}	10.972	Sd	1 1/8	5/16	28.575 ^{+0.0254}	7.937 ^{+0.051}	32.105
DNB	7/16	3/32	11.112 ^{+0.0254}	2.382 ^{+0.051}	12.293	Js	1 1/4	1/4	31.75 ^{+0.0254}	6.35 ^{+0.051}	34.721
T	1/2	3/16	12.7 ^{+0.0254}	4.762 ^{+0.051}	14.757	K	1 1/4	5/16	31.75 ^{+0.0254}	7.937 ^{+0.051}	35.331
Ta	1/2	1/8	12.7 ^{+0.0254}	3.175 ^{+0.051}	14.224	Ma	1 3/8	5/16	34.925 ^{+0.0254}	7.937 ^{+0.051}	38.557
DNC	17/32	1/8	13.495 ^{+0.0254}	3.175 ^{+0.051}	15.011	RH1	1 3/8	3/8	34.925 ^{+0.0254}	9.525 ^{+0.063}	39.141
Do	9/16	1/8	14.287 ^{+0.0254}	3.175 ^{+0.051}	15.824	Cb	1 7/16	3/8	36.512 ^{+0.0254}	9.525 ^{+0.063}	40.767
E	5/8	1/8	15.875 ^{+0.0254}	3.175 ^{+0.051}	17.424	Ca	1 1/2	5/16	38.1 ^{+0.0254}	7.937 ^{+0.051}	41.783
Es	5/8	5/32	15.875 ^{+0.0254}	3.968 ^{+0.051}	17.729	C	1 1/2	3/8	38.1 ^{+0.0254}	9.525 ^{+0.0635}	42.392
Ed	5/8	3/16	15.875 ^{+0.0254}	4.762 ^{+0.051}	18.008	Nb	1 5/8	3/8	41.275 ^{+0.0254}	9.525 ^{+0.0635}	45.618
DNH	11/16	3/16	17.462 ^{+0.0254}	4.762 ^{+0.051}	19.634	Ls	1 3/4	3/8	44.45 ^{+0.0254}	9.525 ^{+0.0635}	48.818
Ad	3/4	1/8	19.05 ^{+0.0254}	3.175 ^{+0.051}	20.624	L	1 3/4	7/16	44.45 ^{+0.0254}	11.112 ^{+0.0635}	49.428
A	3/4	3/16	19.05 ^{+0.0254}	4.762 ^{+0.051}	21.259	Lu	1 7/8	1/2	47.625 ^{+0.0254}	12.7 ^{+0.0635}	53.238
G	7/8	3/16	22.225 ^{+0.0254}	4.762 ^{+0.051}	24.485	Da	1 15/16	1/2	49.212 ^{+0.0254}	12.7 ^{+0.0635}	54.864
F	7/8	1/4	22.225 ^{+0.0254}	6.35 ^{+0.051}	25.069	Ds	2	1/2	50.8 ^{+0.0254}	12.7 ^{+0.0635}	56.464
Gf	15/16	1/4	23.812 ^{+0.0254}	6.35 ^{+0.051}	26.695	Pa	2 1/8	1/2	53.975 ^{+0.0381}	12.7 ^{+0.063}	59.69
H	1	3/16	25.4 ^{+0.0254}	4.762 ^{+0.051}	27.686	U	2 1/4	1/2	57.15 ^{+0.0381}	12.7 ^{+0.063}	62.915
Hs	1	1/4	25.4 ^{+0.0254}	6.35 ^{+0.051}	28.295	Ub	2 3/8	5/8	60.325 ^{+0.0381}	15.875 ^{+0.076}	67.335
R	1 1/16	3/16	26.987 ^{+0.0254}	4.762 ^{+0.051}	29.286	Wd	3 3/8	7/8	85.725 ^{+0.0381}	22.225 ^{+0.076}	95.504
Sb	1 1/8	1/4	28.575 ^{+0.0254}	6.35 ^{+0.051}	31.521	Wf	3 5/8	7/8	92.075 ^{+0.0381}	22.225 ^{+0.076}	101.955

The splines and inch bores specified are only a part of KTR's options. Many other variants are available, too.